

Spicer[®] Electrified[™] e-Axle

eS211

Benefits

- Conventional axle driven by electric motor
- High driveline efficiency
- Modular motor interface to fit all motor technologies
- Minimal impact on vehicle frame
- Compatible with multiple motor diameters and sizes
- Wide range of motors to meet performance requirements

Features

- Peak power: 75,5 kW (96V) or 33,8 kW (48V)
- Continuous output power: 32 kW (96V) or 15,5 kW (48V)
- Peak output torque (nominal): 20 kNm
- DC voltage range (V): 48 to 96V

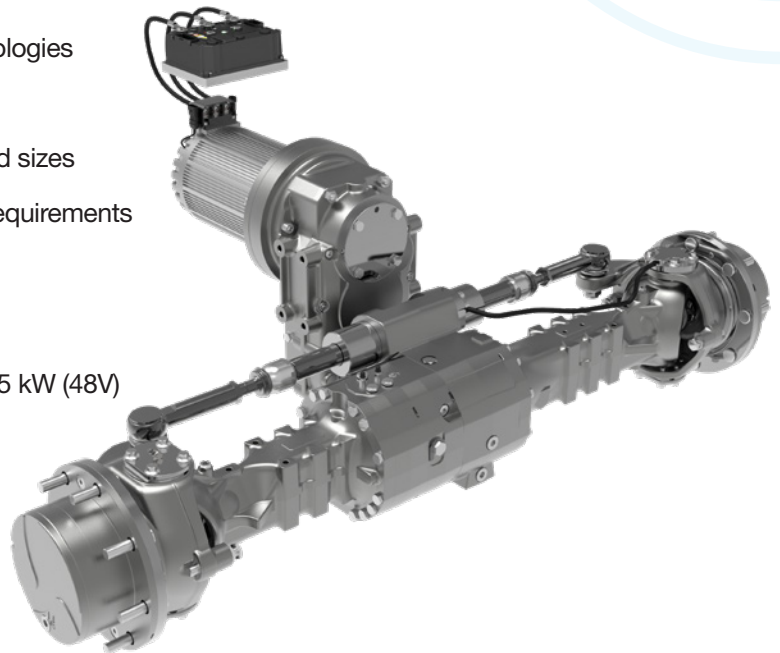

Ideal for Aerial Work Platforms & Telehandlers

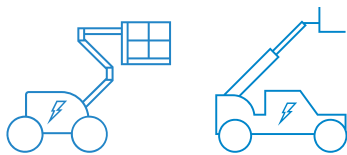

Dana.com/Electrified

Application Policy

Capacity ratings, features, and specifications vary depending upon the model and type of service. Application approvals must be obtained from Dana; contact your representative for application approval. We reserve the right to change or modify our product specifications, configurations, or dimensions at any time without notice.